

LINE 160 | MULTIPOLE VALVES

MP valve islands can be considered real integrated systems. Besides their remarkable flexibility in usage and outstanding performance, we have chosen to add a strong aesthetic feature, focusing on "design" during the planning phase. The wide availability of modules having different configurations allows meeting any application requirement at best, while the integration of valves electrical cabling reduces drastically cabling times of the valve island. The possibility of assembling up to 16 double solenoid valves enables the maximum streamlining of the pneumatic circuit in each system. Finally, the great versatility of this product is confirmed even when assembling the complete valve island. In fact, you can choose between two different fixings methods: by means of DIN rail or through Feet.



AIR PREPARATION

VALVES

CYLINDERS

FITTINGS

GENERAL TECHNICAL DATA

Fluid	filtered air with or without lubrication (in case lubrication is needed, it must be constant)
Working Temp	-5÷50°C (23÷122°F) Please note: Below 3°C the air of the circuit must be free from humidity
Max Valves Q.ty	16
Max. Pilot q.Ty	32
Voltage	24 V DC 310%
Potenza Singolo Pilota	1 W * see note
Electrical Configuration	PNP
Electric Connection	multipole connector 25 pin (up to 10 valve positions) multipole connector 44 pin (from 11 to 16 valve positions)
Degree of protection	IP65: standard multipole connection 25 and 44 pin single cabling with connector and seal

WORKING PRESSURE

Function	Pilot supply	Operating pressure	Pilot operating pressure	Flow Rate Diam.8mm (6=Bar; Dp=1bar)
5/2 monostable	internal (1)	2,5 - 8 bar	(*)	1000 NI/min
	external (12-14)	vacuum - 10 bar	2,5 - 8 bar	
5/2 bistable	internal (1)	2,5 - 8 bar	(*)	1000 NI/min
	external (12-14)	vacuum - 10 bar	2,5 - 8 bar	
5/3	internal (1)	2,5 - 8 bar	(*)	850 NI/min
	external (12-14)	vacuum - 10 bar	2,5 - 8 bar	
3/2 + 3/2	internal (1)	3,2 - 8 bar	(*)	800 NI/min
	external (12-14)	vacuum - 10 bar	3,2 - 8 bar	
3/2	internal (1)	3,2 - 8 bar	(*)	800 NI/min
	external (12-14)	vuoto / vacuum - 10 bar	3,2 - 8 bar	

(*) Attention the pilot supply pressure max: 7bar. An higher pressure may cause malfunctioning of the valve

LINE MP 160 | GENERAL FEATURES

AIR PREPARATION

VALVES

CYLINDERS

FITTINGS

Multi-P valve islands have been developed for guaranteeing the utmost reliability over time.

For ensuring pneumatic tightness, even under particular stress, we have adopted an assembling system of traditional type, by means of screws.

For guaranteeing transmission of electrical signal, even in case of troubling vibrations, we made the choice of mounting just one electronic card of hard type.

The electrical control part (solenoid pilot) can be easily checked, also when the valve island is installed, simply disassembling the upper cover consisting of one integrated module only.

All setting and checking operations can be carried out from outside on the installed island. The manual override of each valve and Led for visual check are positioned within easy reach on the upper part of cover.

All pneumatic connections are complete with inbuilt push-in fitting and positioned on one side so as to make pipes mounting easier.

Then, the electrical connection of the system consists of a SUB-D 25 or 44 Pin connector, according to the valve island dimensions.

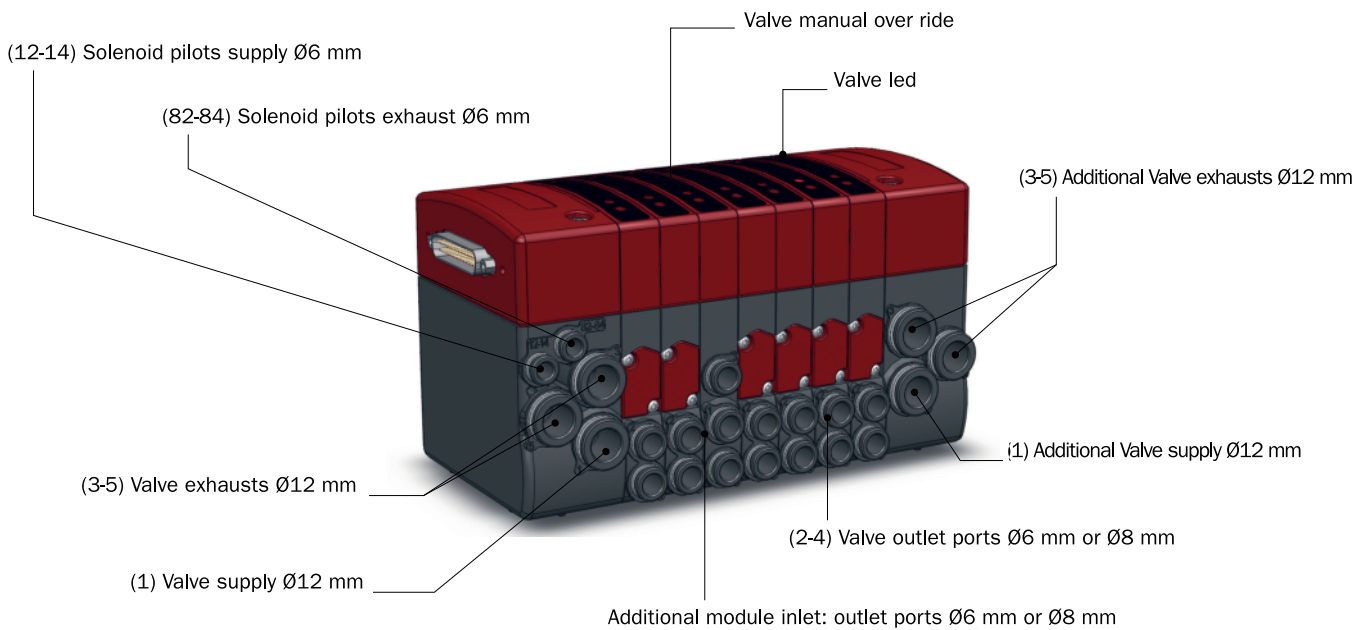
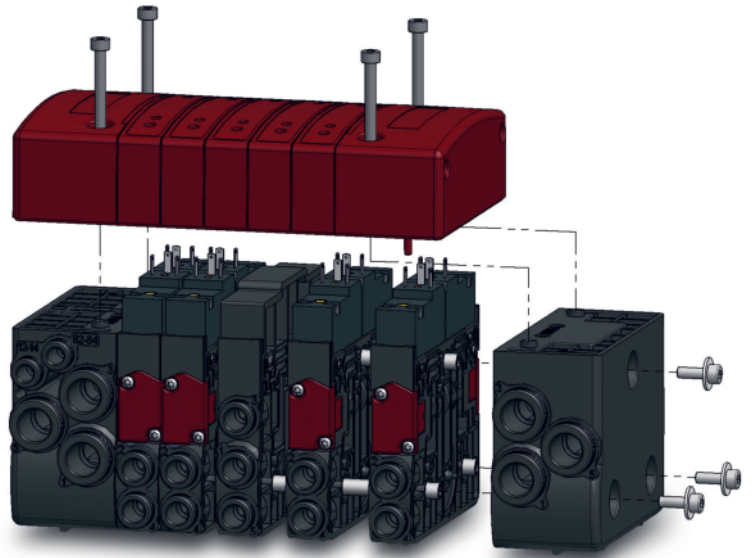

LINE MP 160 | DIMENSIONS

SINGLE CABLING WITH CONNECTOR DIMENSIONS

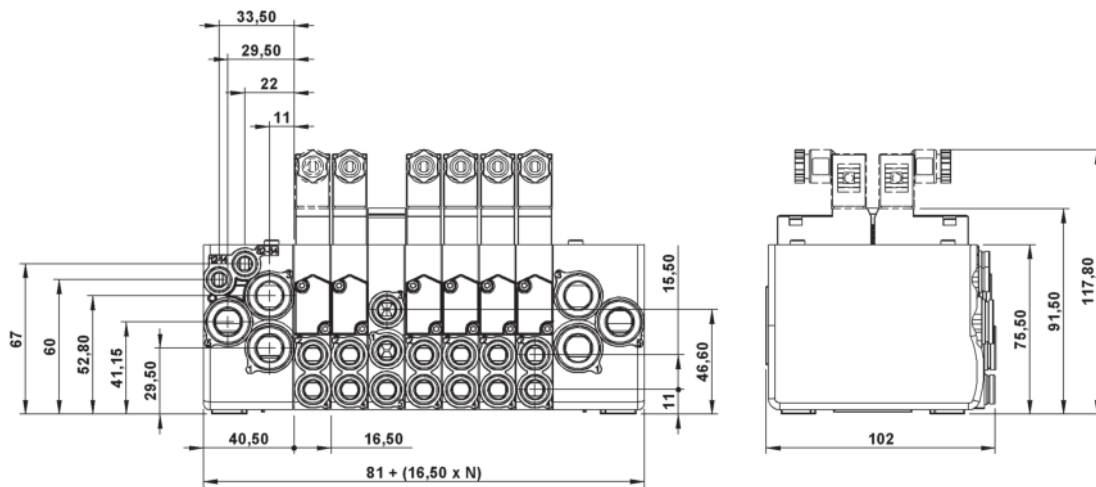

MULTIPOLE CABLING DIMENSIONS

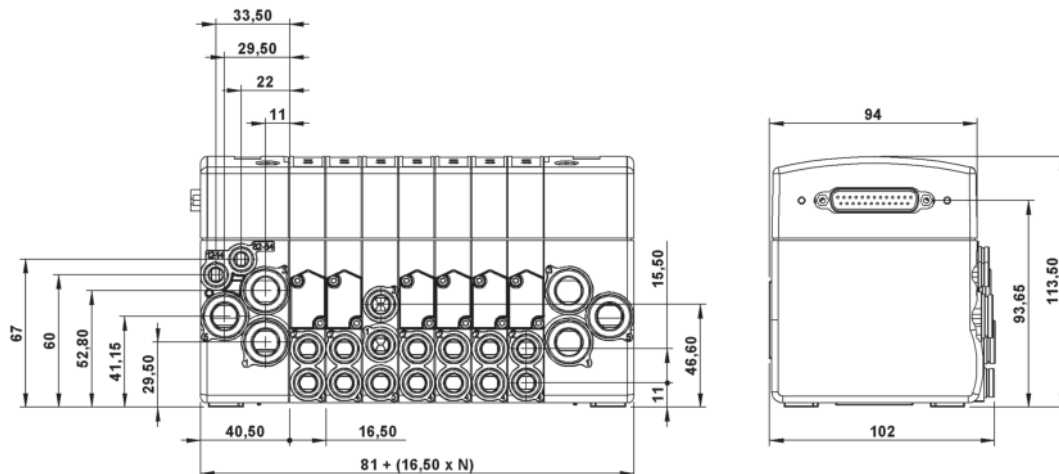

ASSEMBLING KIT DIMENSIONS

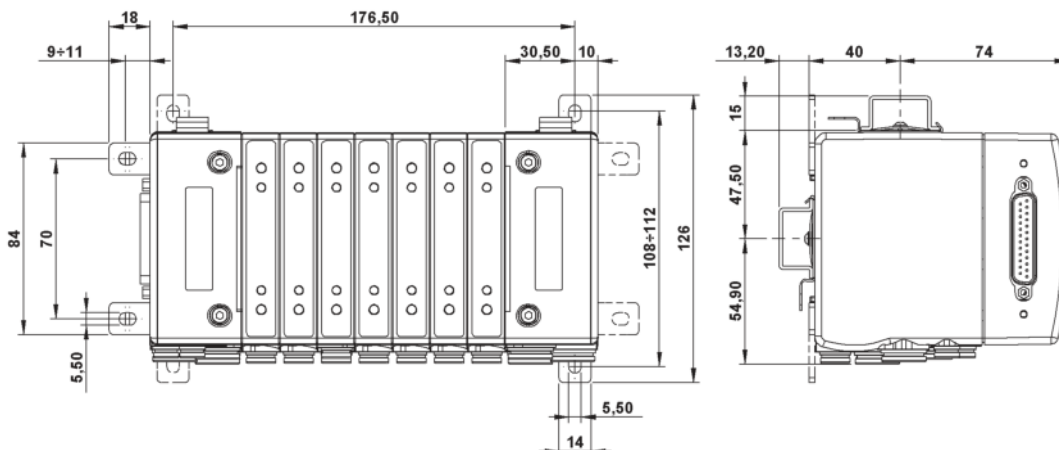

AIR PREPARATION

VALVES

CYLINDERS

FITTINGS

LINE MP 160 | BATTERY FIXING

FIXING BY MEANS OF DIN EN 60715 ON REAR

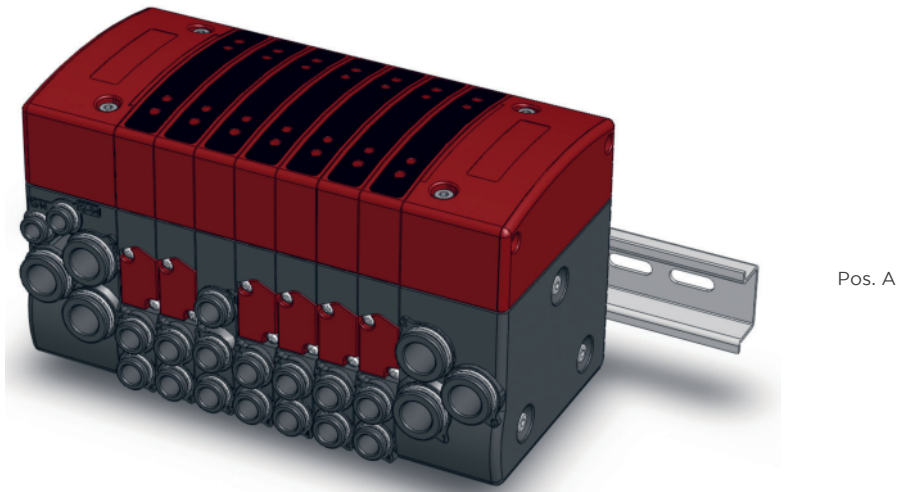

FIXING BY MEANS OF DIN EN 60715 RAIL ON BASE

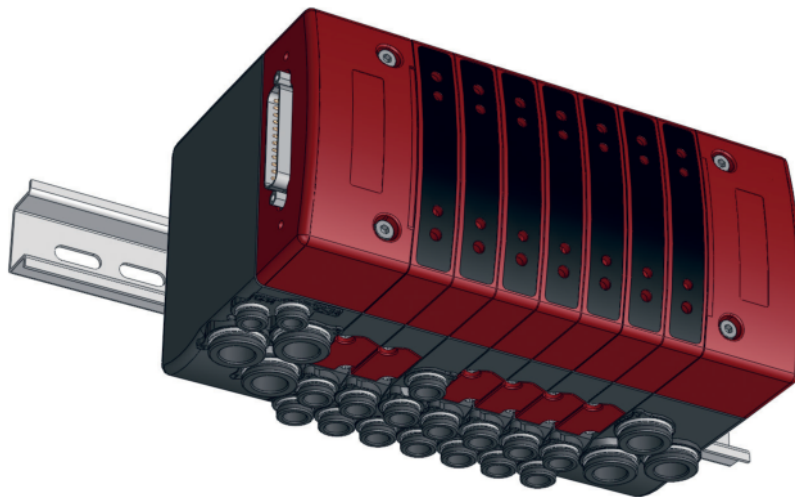

FIXING BY MEANS OF STRAIGHT OR SIDE FEET

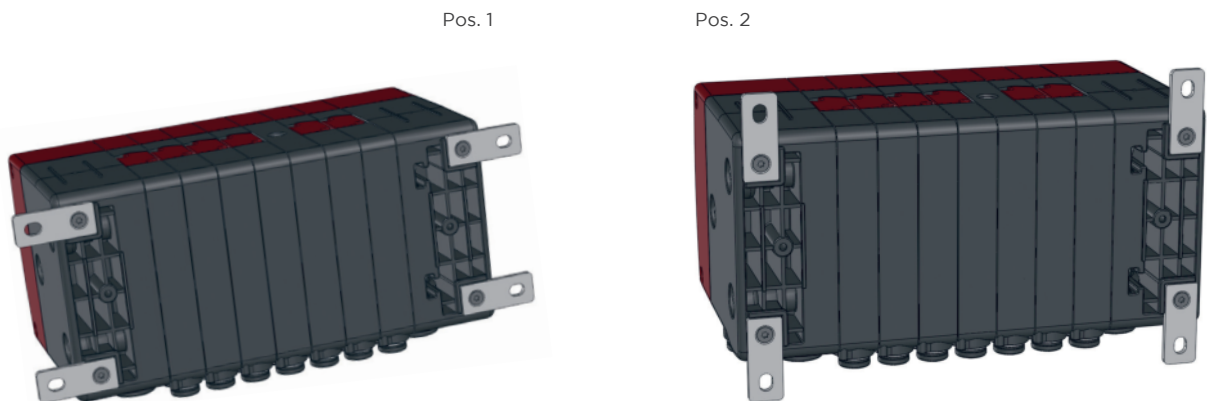

LINE MP 160 | BATTERY ARRANGEMENT

We made the choice of supplying the valve island already assembled according to Customer's specifications, with a view to ensure that any produced part undergoes the final pneumatic and electrical testing on the basis of set standard parameters.

The valve island configuration can be defined by means of the reference guide you find hereunder.

In fact, reference is the "explaining" key, summarizing the information

about the valve island at issue.

Description will be essential for asking information, calculating the price of the whole valve island and ordering it complete.

Then, an identification code will be attached to the complete island, through which it will be possible to re-order quickly and safely the product and allow any operator to identify clearly the configuration, at any time.

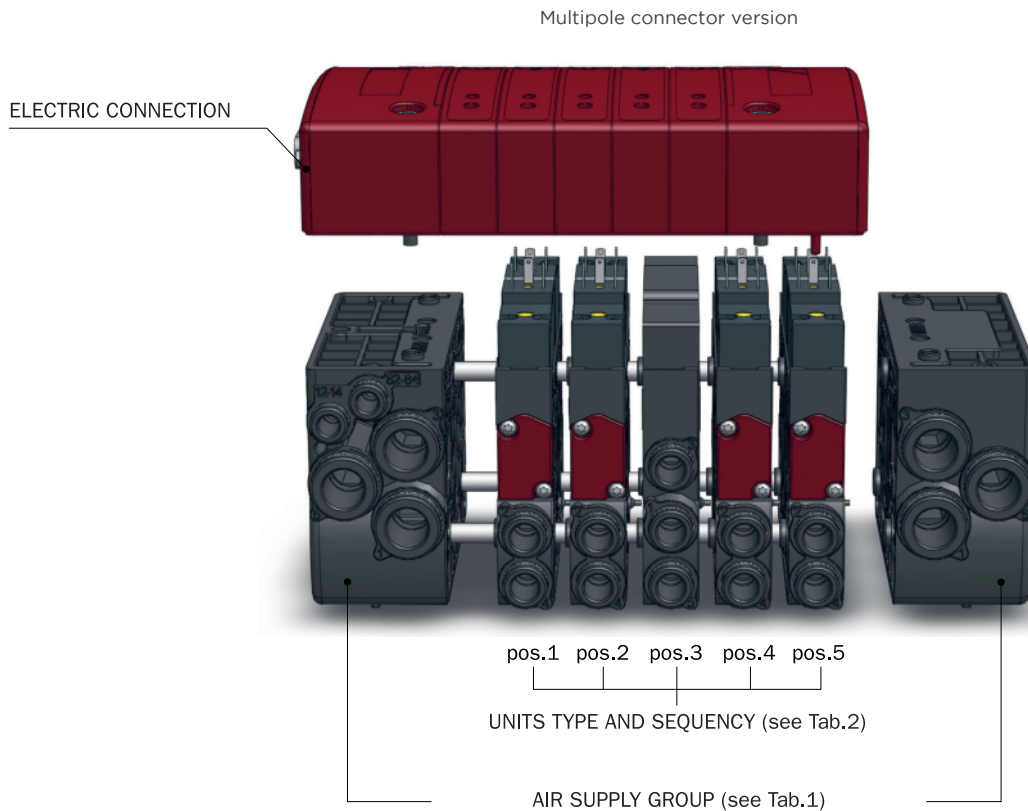

Single cabling with connector version



LINE MP 160 | BATTERY ARRANGEMENT

AIR PREPARATION

VALVES

CYLINDERS

FITTINGS

GUIDE TO REFERENCES

MP160 5 025 B VA8-VB8-MZ8-VB8-VF6

<p>Product</p> <p>MP160 = Valves Battery line 160</p>	<p>Units Position And Sequence (See Tab.2 And Tab.3)</p> <p>Pos.1 = VA8</p> <p>Pos.2 = VB8</p> <p>Pos.3 = MZ8</p> <p>Pos.4 = VB8</p> <p>Pos.5 = VF6</p>
<p>Total Positions Number (from 2 to 16 max. positions)</p> <p>5 = 5 positions</p>	<p>Pneumatic Supply Type</p> <p>B = see Tab.1</p>
<p>Electric Connection</p> <p>025 = SUB-D 25 pin (up to 10 valve positions)</p> <p>044 = SUB-D 44 pin (from 11 to 16 valve positions)</p> <p>CON = connector individual wiring</p>	

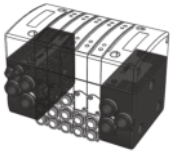

TAB. 1 - AIR SUPPLY: POSSIBLE CONFIGURATIONS

CONFIGURATION	DESCRIPTION	PILOT SUPPLY	PORTS 1, 3, 5	PORT 12-14	PORT 82-84	REFERENCE
	air supply in Left End Plate - Right End Plate closed internal pilot supply external pilot exhaust	from port (1)	Ø12 mm	closed	Ø6 mm	A
	air supply in both End Plates external pilot exhaust	from port (1)	Ø12 mm	closed	Ø6 mm	B
	Right End Plate closed external pilot supply	from port (12-14)	Ø12 mm	Ø6 mm	Ø6 mm	C
	air supply in both End Plates external pilot supply	from port (12-14)	Ø12 mm	Ø6 mm	Ø6 mm	D

LINE MP 160 | BATTERY ARRANGEMENT

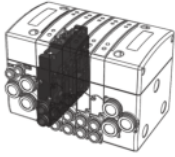

TAB. 2 - VALVES

FUNCTION	PILOT	RETURN	SYMBOL	PORTS	REFERENCE
5/2 monostable	solenoid	pneumatic spring		automatic Ø6 mm	VA6
				automatic Ø8 mm	VA8
5/2 bistable	solenoid	solenoid		automatic Ø6 mm	VB6
				automatic Ø8 mm	VB8
5/3 CC	solenoid	Spring		automatic Ø6 mm	VC6
				automatic Ø8 mm	VC8
3/2+3/2 NC+NO	solenoid	Spring		automatic Ø6 mm	VD6
				automatic Ø8 mm	VD8
3/2+3/2 NC+NC (5/3 CA)	solenoid	Spring		automatic Ø6 mm	VE6
				automatic Ø8 mm	VE8
3/2+3/2 NO+NO (5/3 CP)	solenoid	Spring		automatic Ø6 mm	VF6
				automatic Ø8 mm	VF8
3/2 NC	solenoid	Spring		automatic Ø6 mm	VG6
				automatic Ø8 mm	VG8
3/2 NO	solenoid	Spring		automatic Ø6 mm	VH6
				automatic Ø8 mm	VH8

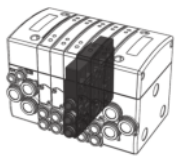

TAB. 3 - ADDITIONAL INTERMEDIATE UNITS

SYMBOL	DESCRIPTION	PORT 1	PORT 3	PORT 5	REFERENCE
	additional supply port to the right side open exhaust ports on the right closed supply and exhaust ports on the left	automatic Ø6 mm	automatic Ø6 mm	automatic Ø6 mm	MZ6
		automatic Ø8 mm	automatic Ø8 mm	automatic Ø8 mm	MZ8
	blanking plate	closed	closed	closed	MX
	spacing module (vacant valve position)	closed	closed	closed	MS
	additional supply module	automatic Ø6 mm	automatic Ø6 mm	automatic Ø6 mm	MR6
		automatic Ø8 mm	automatic Ø8 mm	automatic Ø8 mm	MR8